

MCRN2P RFID Reader

PoE-Ethernet, RGB-LED



The **MCRN2P** is a robust outdoor RFID reader equipped with a tri-colour LED, designed for secure access control in various environments. Ideal for a wide range of access points, it ensures reliable and efficient management of authorized entries. With its durable build, it's suited for all-weather conditions, making it a dependable choice for high-security areas. The LED provides clear instructions, enhancing user experience and operational efficiency. Perfect for locations requiring stringent access management, such as depots or logistics hubs.

Key features

- Waterproof**
 This Device is suitable for outdoor environments (IP65)
- Transponders**
 MIFARE® Family (Classic, DESFire, Ultralight)
 NTAG, I-Code, NFC-enabled smartphones
- Relays**
 2xSolid State Relays 1.2A / 30V
- Interface**
 RS232, RS485, Ethernet PoE
- Supported Standards**
 ISO14443A/B, ISO15693
- Power Supply**
 +8V to +60V DC Or Pover over Ethernet
- Antenna**
 Internal antenna for compact design
- LED Indicator**
 RGB LED for clear visual status feedback

Ideal for

- Access Control Systems
- Industrial automation
- EV-Charging stations
- Public Transportation
- Parking & Logistics Management
- Vending & Payment Systems



Access Systems



Logistik Supply chain



EV-Charger



Industrial Automation



Time Tracing



Healthcare



Shop PoS



Public Transport



Parking



ATM



Library



Home Automation



Telemetry Systems

Technical Data

Operating Frequency	13.56 MHz /HF RFID/NFC)	
Dimensions	100X100X25mm	
MTBF	500.000h	
Interfaces	Ethernet (PoE-Enabled) RS232 RS485 2x Solid state relays (1.2V / 30V)	
Supported Cards & Transponders	MIFARE® Classic MIFARE® Ultralight MIFARE® DESFire NTAG I-Code NFC Phones	
Antenna	Integrated	
LED	RGB LED indicator for status feedback	
Temperature	-40°C to +85 °C	
Relative Air Humidity	5% up to 95% (non-condensing)	
Power Supply	+12VDC Or PoE (+8V to +60V range)	
Current Consumption	~50-200 mA at +12V	
Weight	200 g	
Supported Standards	ISO14443A/B ISO15693	
Certifications	USA Europe/UK	FCC 47 CFR Part 15 CE/RED
Compliances	Cyber Security EMC Environment	EN 18031-1 EN 301489 EN 55022 EN 300330 RED 2014/53/EU RoHS Compliance REACH 1907/2006

Ordering Code

Article Nr.	Interface	Relay	Input	RS232	RS485	Waterproof	Power Supply	Output Type
MCRN2P-2210	PoE	2	2	1	1		PoE or Vin	Open Output
MCRN2P-221V	Passive-PoE	2	2	1	1		+12VDC	Open Output
MCRN2P-2100R	PoE					IP65	PoE	Rear Output
MCRN2P-2100S	PoE					IP65	PoE	Side Output
MCRN2P-2200R	PoE	2				IP65	PoE	Rear Output
MCRN2P-2200S	PoE	2				IP65	PoE	Side Output
MCRN2P-WM10/20	Wall Mount Bracket H=10mm or 20mm							

Article number: MCRN2P-XXXX_

S = Side cable output

R = Rear cable output

Dimensions & Mounting

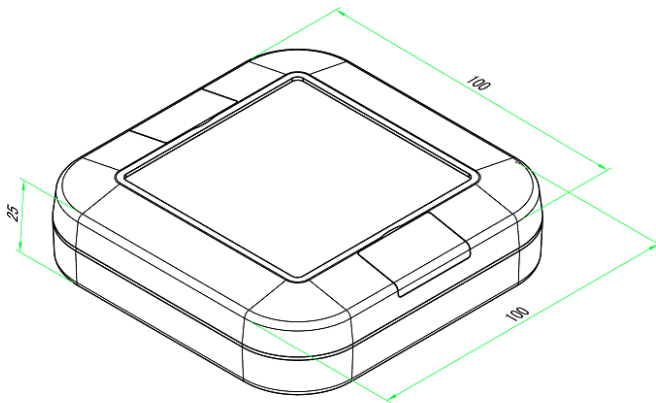

100 x 100 x 25 mm



Blind lids for wall mounting

Rear Output	Side Output	Open Outputs
Ethernet Only	Ethernet Only	Ethernet + Relays + Inputs+ RS232/485
Ethernet + Relay Cable	Ethernet + Relay Cable	Wall mount bracket 10mm/20mm
Relay Cable Pinning		
<ul style="list-style-type: none"> — Brown [RELAY1] — Yellow [RELAY1] — Green [RELAY2] — White [RELAY2] 		
RS232/RS485 Cable Pinning		
<ul style="list-style-type: none"> — Brown [+VIN] — Yellow [TX-OUT][A] — Green [RX-IN][B] — White [GND] 		

FCC Regulatory Conformance

Radiation Exposure Statement

This equipment complies with FCC radiation exposure limits set forth for an uncontrolled environment. This equipment should be installed and operated at a minimum distance of 20cm between the radiator and your body.

NOTE: This equipment has been tested and found to comply with the limits for a Class A digital device, pursuant to part 15 of the FCC Rules. These limits are designed to provide reasonable protection against harmful interference in a residential installation. This equipment generates uses and can radiate radio frequency energy and, if not installed and used in accordance with the instructions, may cause harmful interference to radio communications. However, there is no guarantee that interference will not occur in a particular installation. If this equipment does cause harmful interference to radio or television reception, which can be determined by turning the equipment off and on, the user is encouraged to try to correct the interference by one or more of the following measures:

- Reorient or relocate the receiving antenna.
- Increase the separation between the equipment and receiver.
- Connect the equipment into an outlet on a circuit different from that to which the receiver is connected.
- Consult the dealer or an experienced radio/TV technician for help.

FCC Part 15.19 Warning Statement- (Required for all Part 15 devices)

THIS DEVICE COMPLIES WITH PART 15 OF THE FCC RULES. OPERATION IS SUBJECT TO THE FOLLOWING TWO CONDITIONS: (1) THIS DEVICE MAY NOT CAUSE HARMFUL INTERFERENCE, AND (2) THIS DEVICE MUST ACCEPT ANY INTERFERENCE RECEIVED, INCLUDING INTERFERENCE THAT MAY CAUSE UNDESIRE OPERATION.

FCC Part 15.21 Warning Statement-

NOTE: THE GRANTEE IS NOT RESPONSIBLE FOR ANY CHANGES OR MODIFICATIONS NOT EXPRESSLY APPROVED BY THE PARTY RESPONSIBLE FOR COMPLIANCE. SUCH MODIFICATIONS COULD VOID THE USER'S AUTHORITY TO OPERATE THE EQUIPMENT.

Minova Technology GmbH

Lindenstraße 2
78628 Rottweil / Germany



info@minovatech.de
+49 (0) 741 348 51 564

The information provided in this datasheet is intended to describe the general characteristics and technical specifications of products manufactured by **Minova Technology GmbH**. It is subject to change without prior notice and does not constitute a guarantee or warranty of any kind. Minova Technology GmbH assumes no responsibility for any errors or omissions that may occur in this document or for the use of the information contained herein.

© 2026 Minova Technology GmbH. All rights reserved.